

Profilübersicht der Systemplattform S 9000

profile system S 9000 - overview

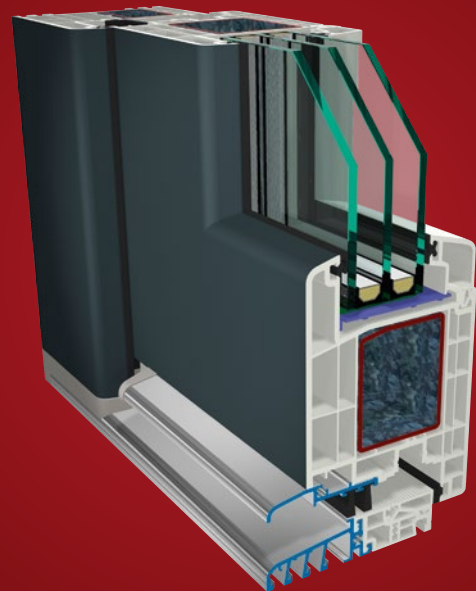
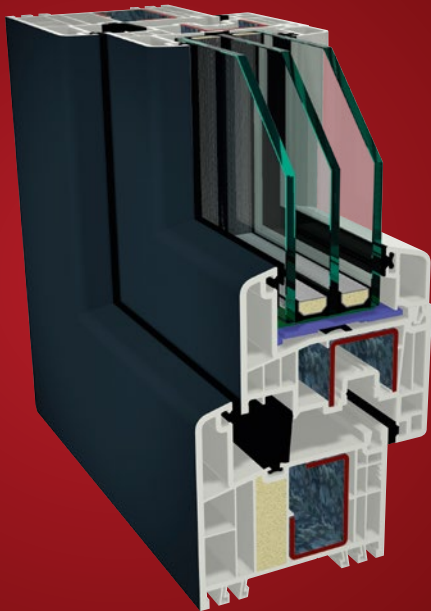
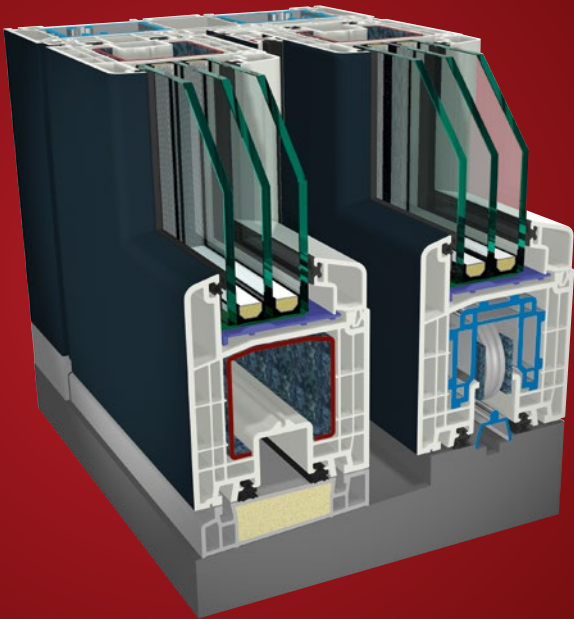

Wärmeisolierend
thermal insulating

Wirtschaftlich
economic

Nachhaltig
sustainable

Innovativ
innovative

Vielseitig
multifunctional

S 9000

INNOVATION MIT SYSTEM

 **GEALAN**

6002 

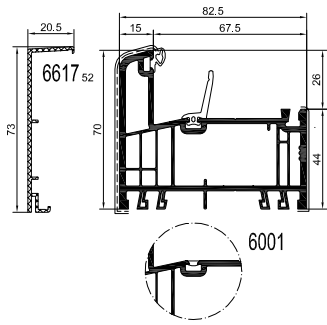

...51	lx	ly	Typ	d
6705	1,81	0,87	□	1,50
6706	2,32	1,13	□	2,00
6708	1,37	0,83	□	1,50
6709	1,49	1,48	□	1,50
6713	4,01	1,09	□	1,50
6714	5,18	1,39	□	2,00
6715	1,67	1,07	□	2,00
6737	1,89	1,87	□	2,00

6016 

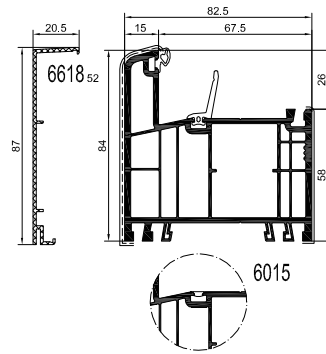

...51	lx	ly	Typ	d
6716	1,76	4,23	□	2,00
6717	1,47	0,43	□	2,00
6718	2,54	5,28	□	2,00
6736	1,39	3,29	□	1,50
6747	2,02	4,16	□	1,50
6757	1,86	4,50	□	2,00

6045 

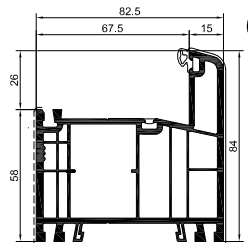

...51	lx	ly	Typ	d
6716	1,76	4,23	□	2,00
6717	1,47	0,43	□	2,00
6718	2,54	5,28	□	2,00
6736	1,39	3,29	□	1,50
6747	2,02	4,16	□	1,50
6757	1,86	4,50	□	2,00

6036 

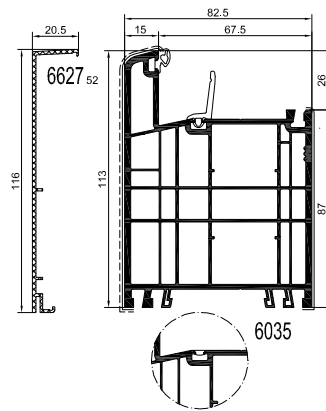

...51	lx	ly	Typ	d
6708	1,30	0,82	□	1,50
6709	1,49	1,48	□	1,50
6715	1,67	1,07	□	2,00
6717	1,47	0,43	□	1,50
6737	1,89	1,87	□	2,00

6048 

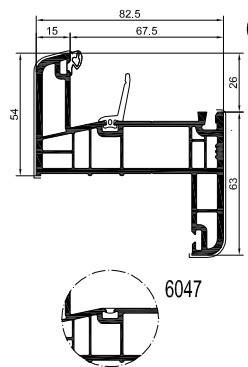

...51	lx	ly	Typ	d
6744	1,24	0,59	□	1,50
6745	1,56	0,73	□	2,00

6032 

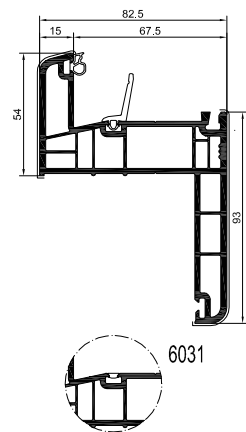



...51	lx	ly	Typ	d
6744	1,24	0,59	□	1,50
6745	1,56	0,73	□	2,00

Pfosten · mullions

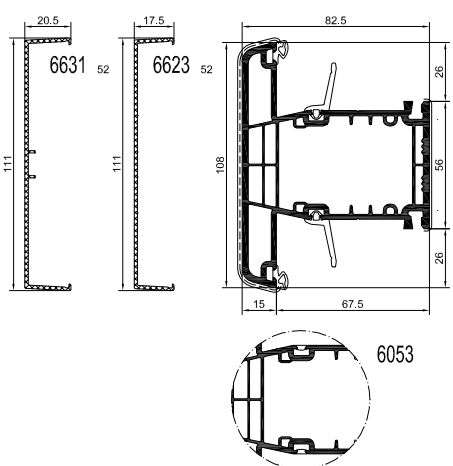

6054 

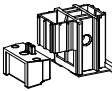

...51	lx	ly	Typ	d
6743	18,02	7,02	□	2,50
6750	14,79	5,88	□	2,00
6754	11,39	4,55	□	1,50

6418⁵⁵  **6442**⁵⁵ 

6465⁷⁰  **6439**  geplant / planned

6466⁸⁰  **6461**⁹⁹ 

6422⁵⁵ 

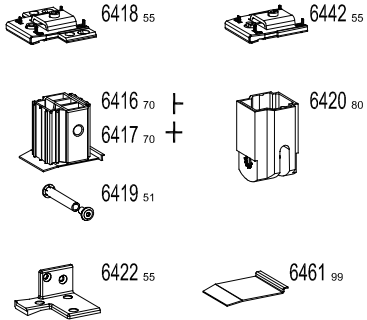
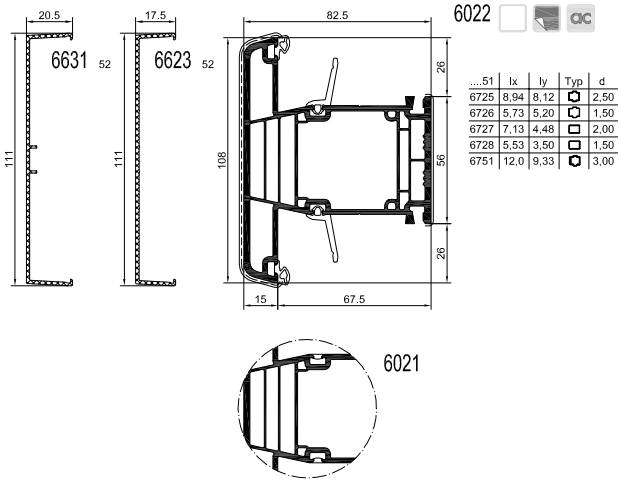
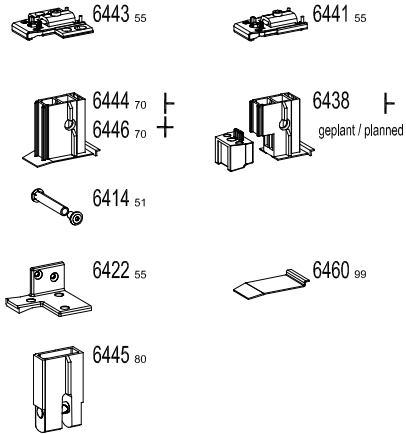
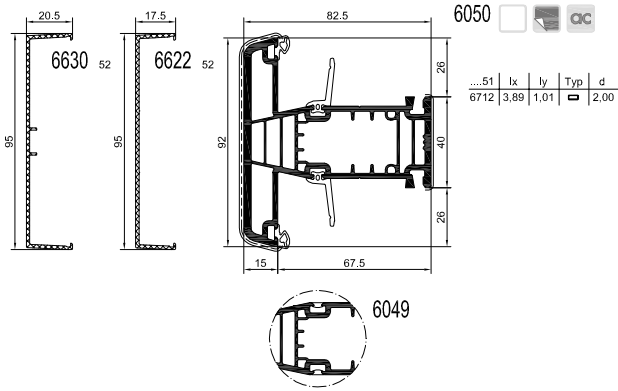

Flügel · sashes

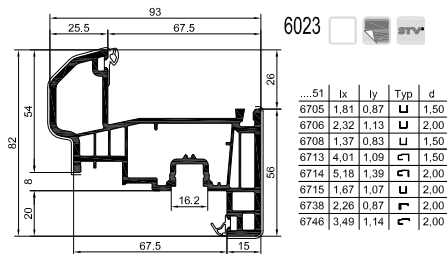
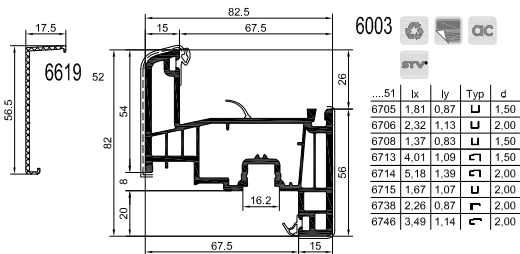
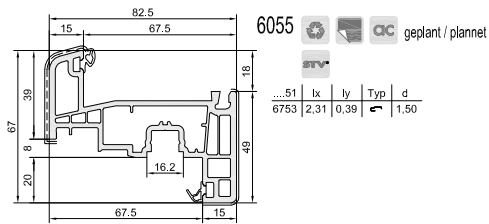

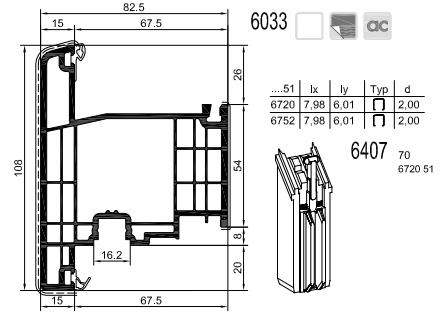
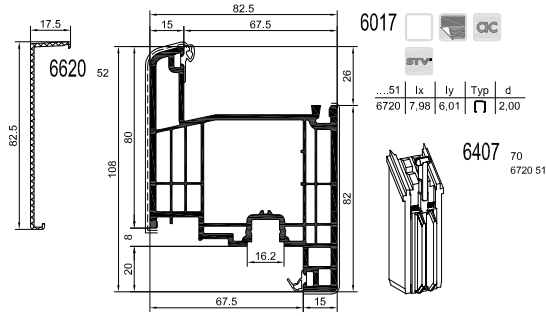

Haustür · front door

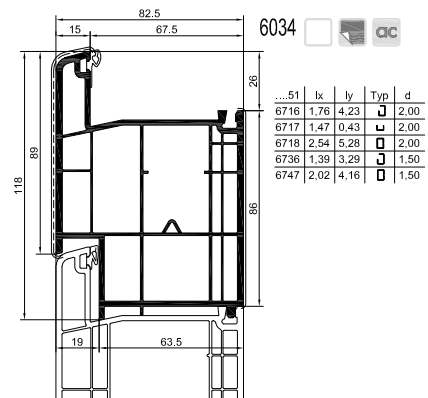
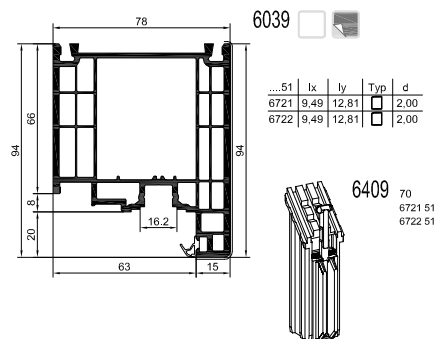
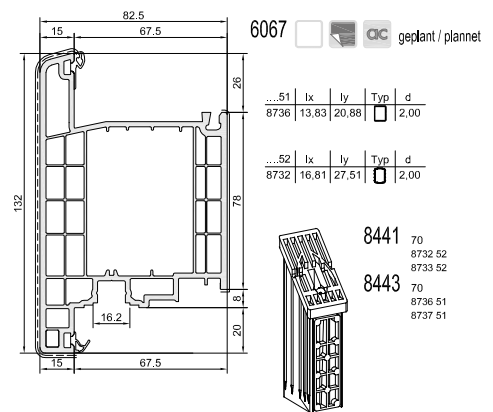
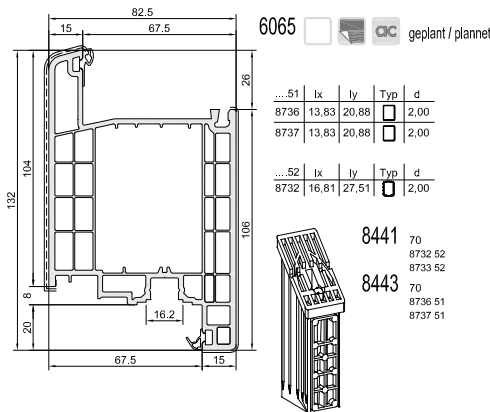
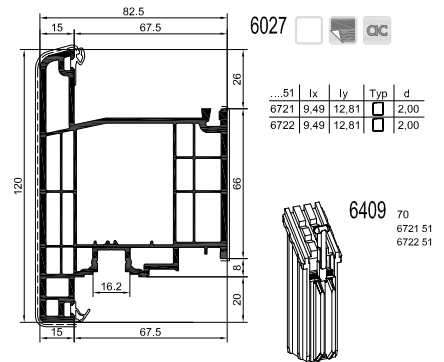
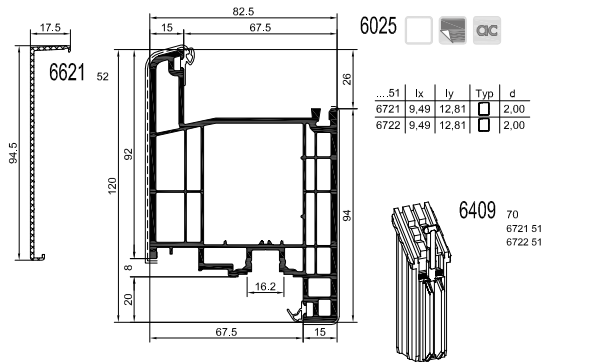

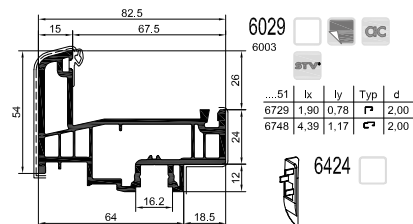
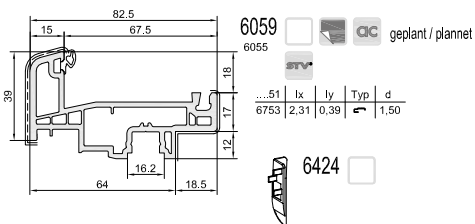
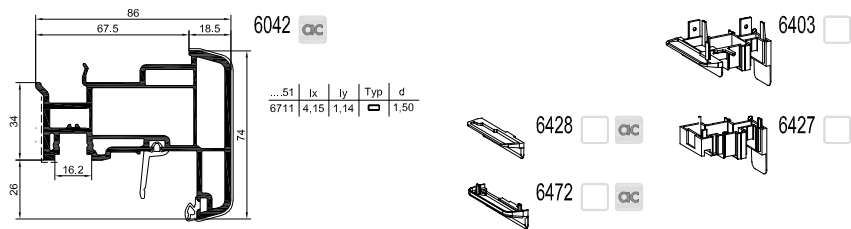
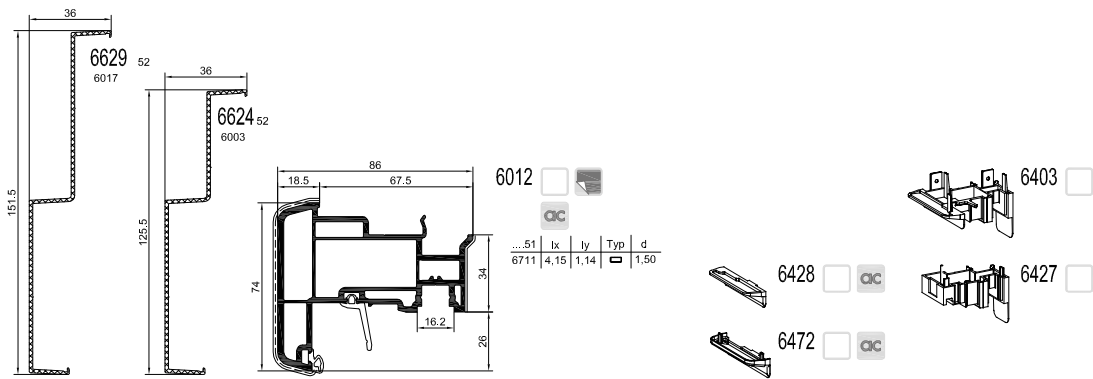
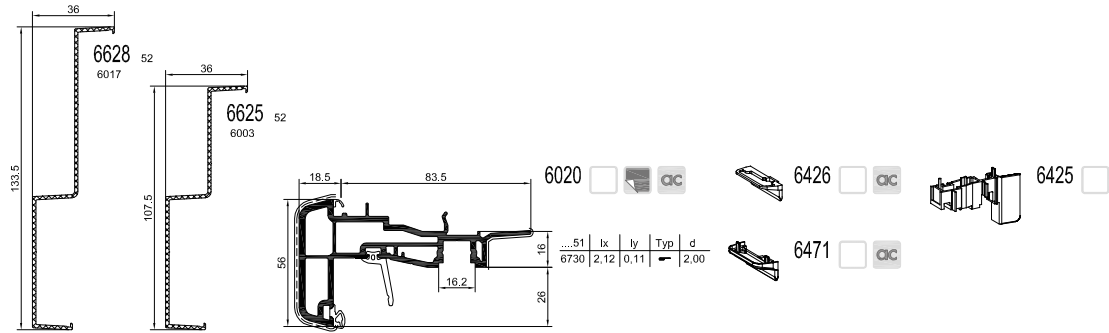
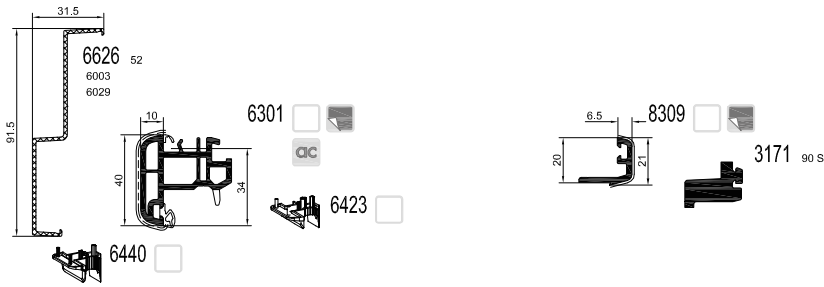

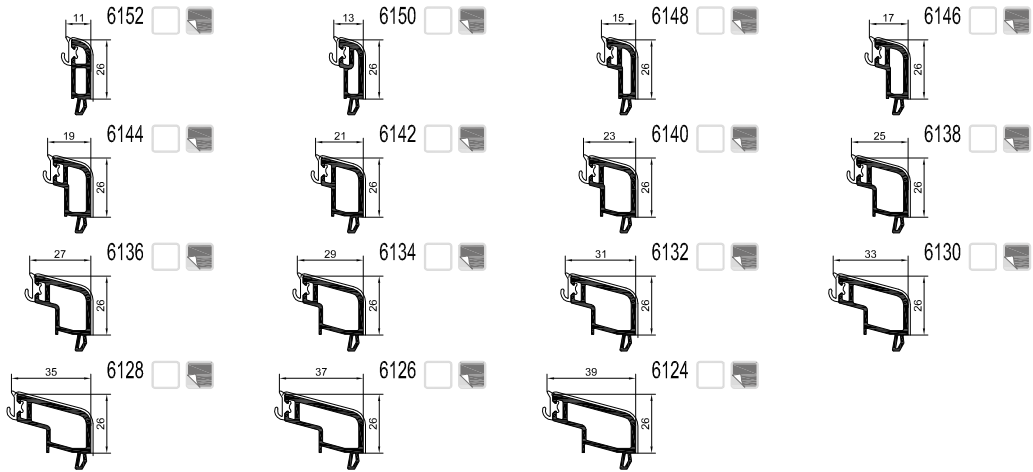

Aussteifungen · reinforcements

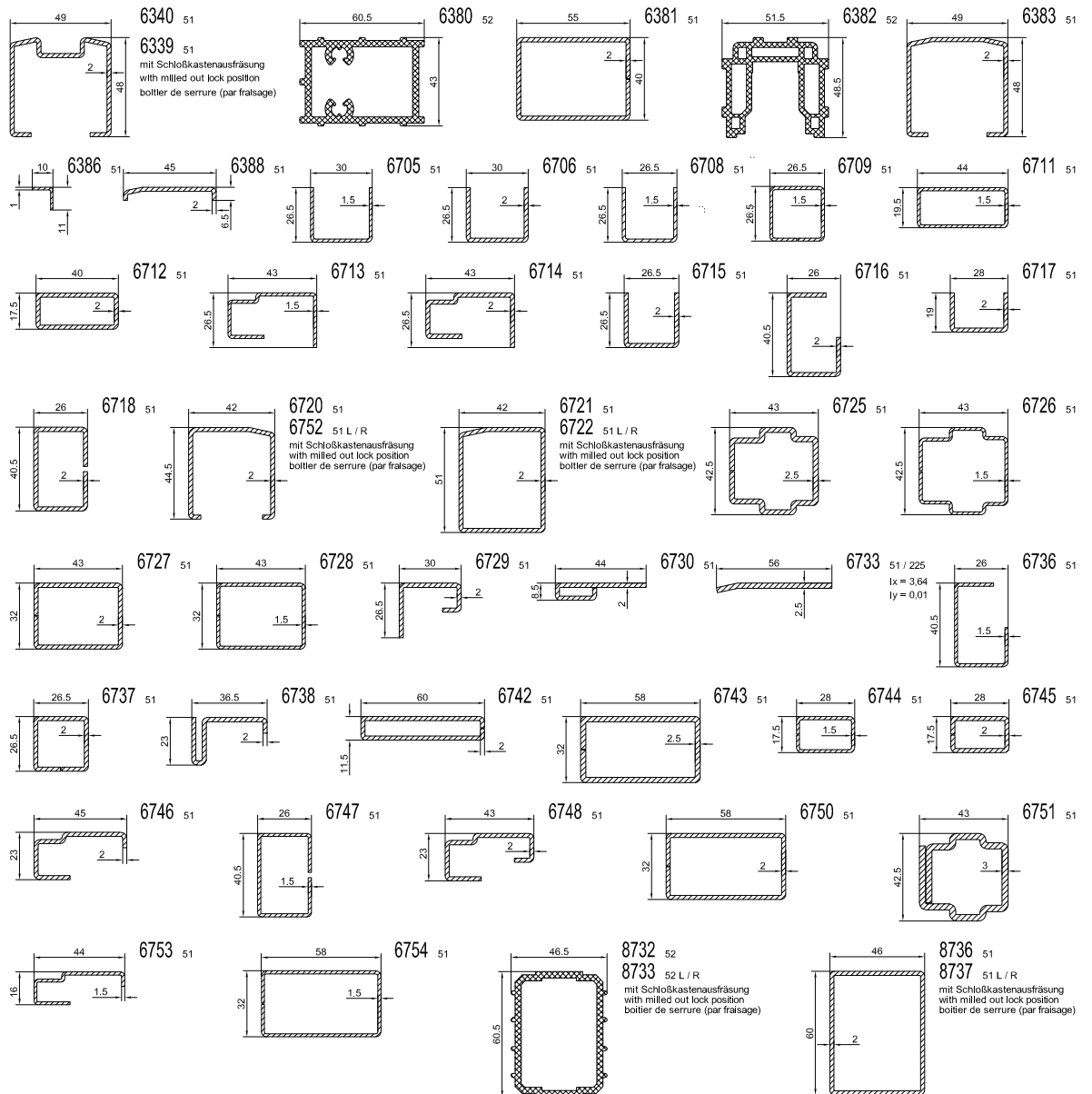

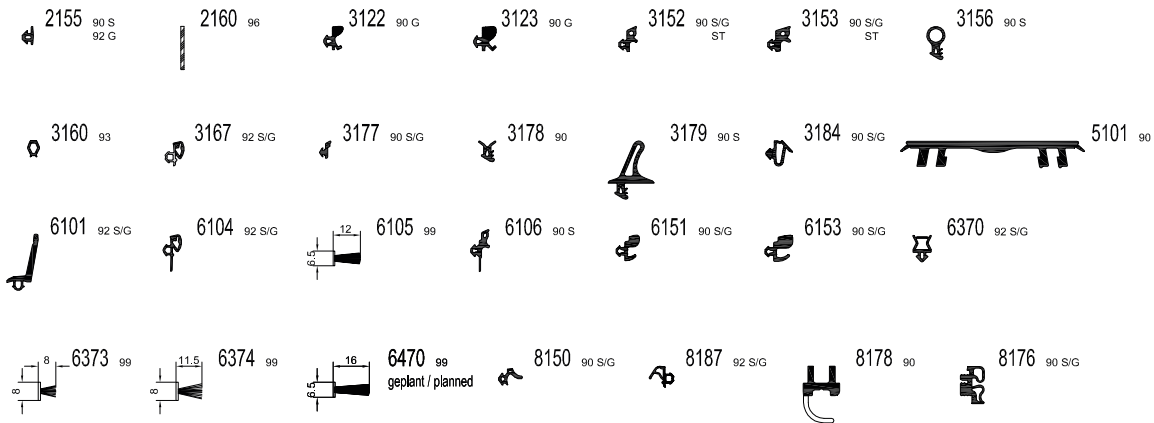

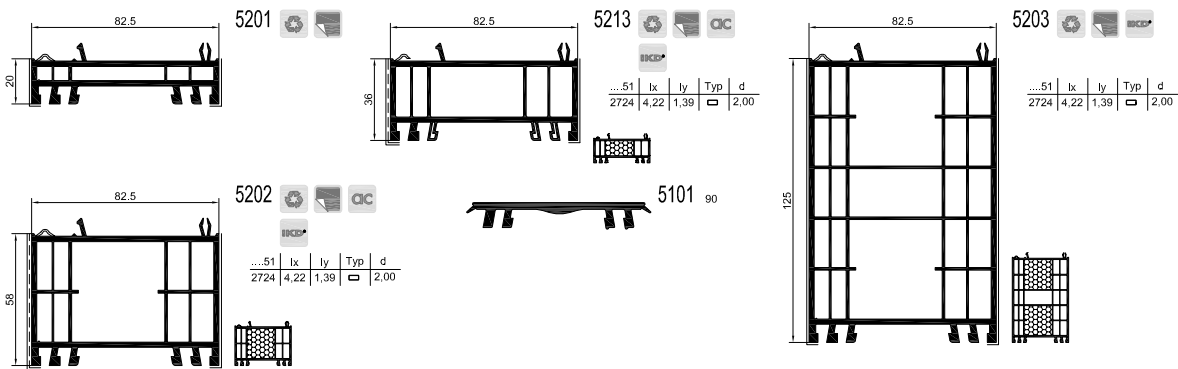

Rahmenverbreiterungen · frame extensions

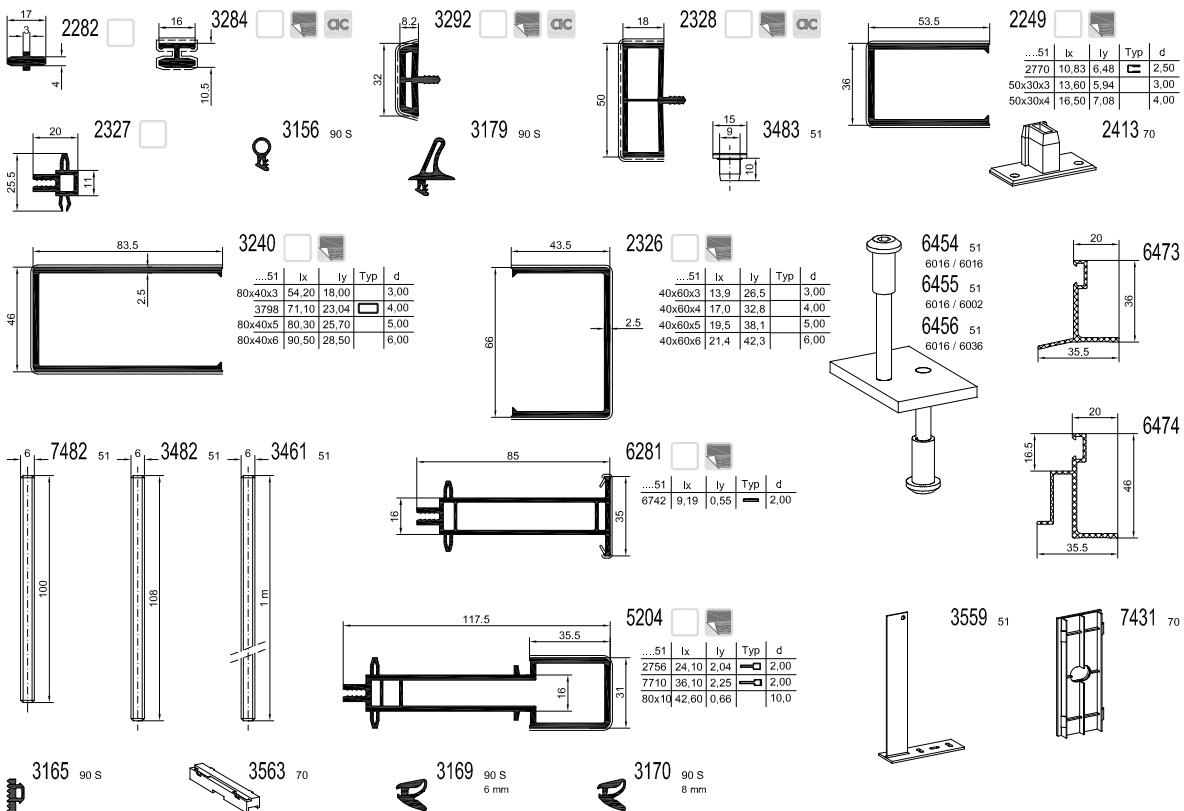

Kopplungsprofile · coupling profiles



2304 

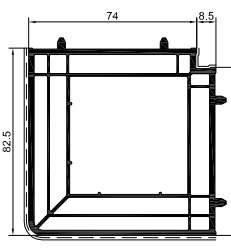



...51	lx	ly	Typ	d
7718	14,37	14,37		2,00
50x50x4	25,00	25,00		4,00
50x50x5	28,90	28,90		5,00

2325 

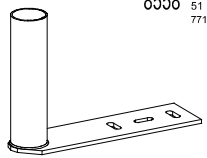

8558 ⁵¹ 7711



5206 

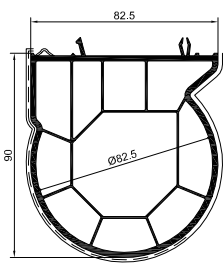

...51	lx	ly	Typ	d
2703	1,91	5,93		2,00
7711	7,54	7,54		2,60

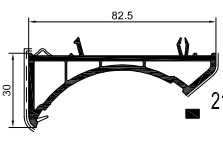

5207 





2172 90 SW





Untere Anschlussprofile · sill profiles

2212  **2230** 

2101 



3216  **3210** 

3205  **3208** 

3206 



2209 

3217 

3215  **2221** 

2211 



3207 

2237  **2239** 

3239 

7213 

7201 

7202  **7205**  **7206** 

6277  geplamt / planned

...51	lx	ly	Typ	d
3710	2,67	2,37		2,00
3712	1,90	1,00		1,50
4794	1,98	1,78		1,50
7701	2,51	2,26		2,00

7209 

6288  geplamt / planned

...51	lx	ly	Typ	d
3710	2,67	2,37		2,00
3712	1,90	1,00		1,50
4794	1,98	1,78		1,50
7701	2,51	2,26		2,00

7288 

...51	lx	ly	Typ	d
3710	2,67	2,37		2,00
3712	1,90	1,00		1,50
4794	1,98	1,78		1,50
7701	2,51	2,26		2,00

7299 

...51	lx	ly	Typ	d
3710	2,67	2,37		2,00
3712	1,90	1,00		1,50
4794	1,98	1,78		1,50
7701	2,51	2,26		2,00

5205 

6299  geplamt / planned

...51	lx	ly	Typ	d
3710	2,67	2,37		2,00
3712	1,90	1,00		1,50
4794	1,98	1,78		1,50
7701	2,51	2,26		2,00

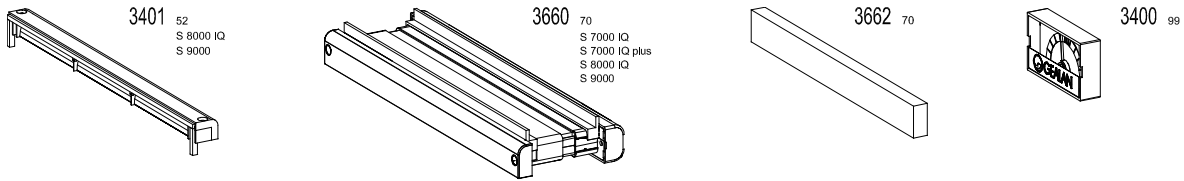

Schwellen · thresholds

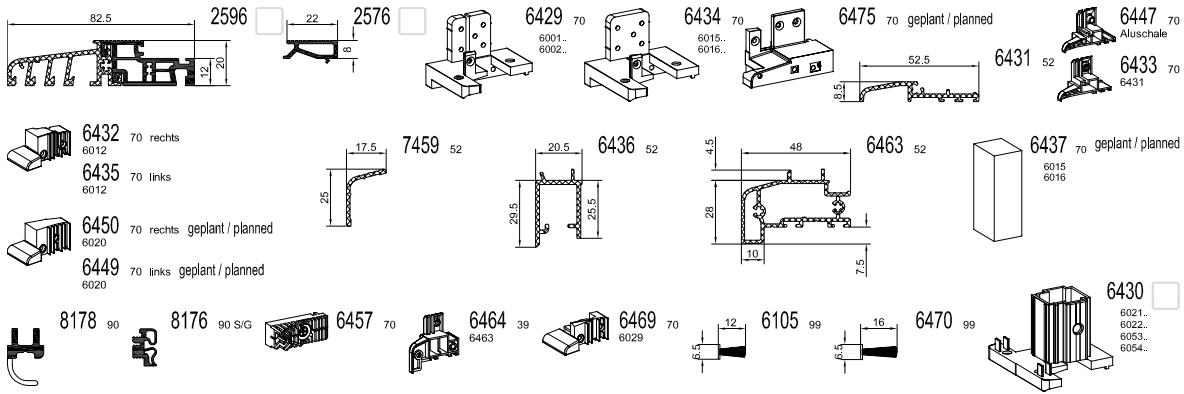

Sonstige · miscellaneous

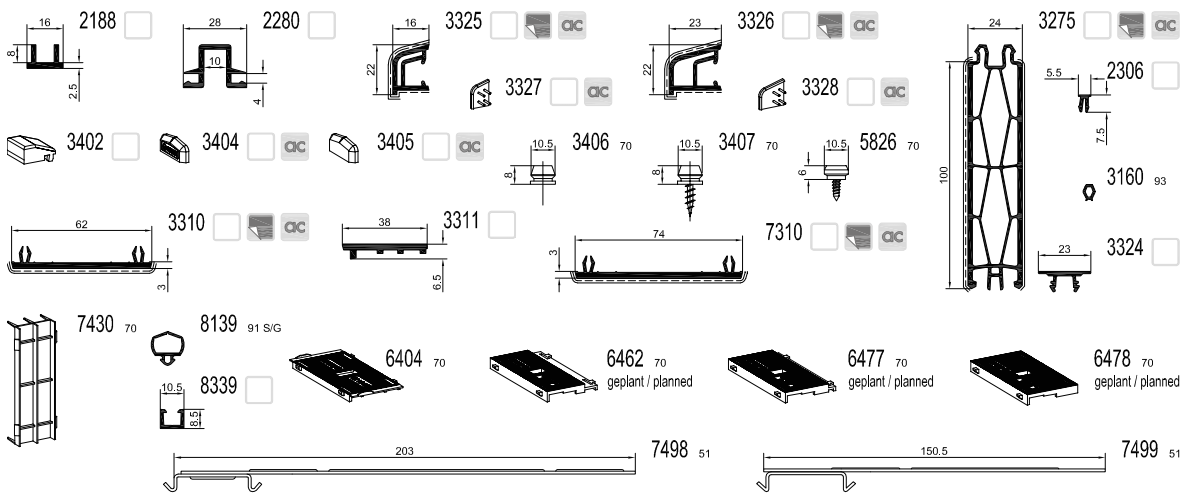

Hebe-Schiebe-Tür · lift-slide-door

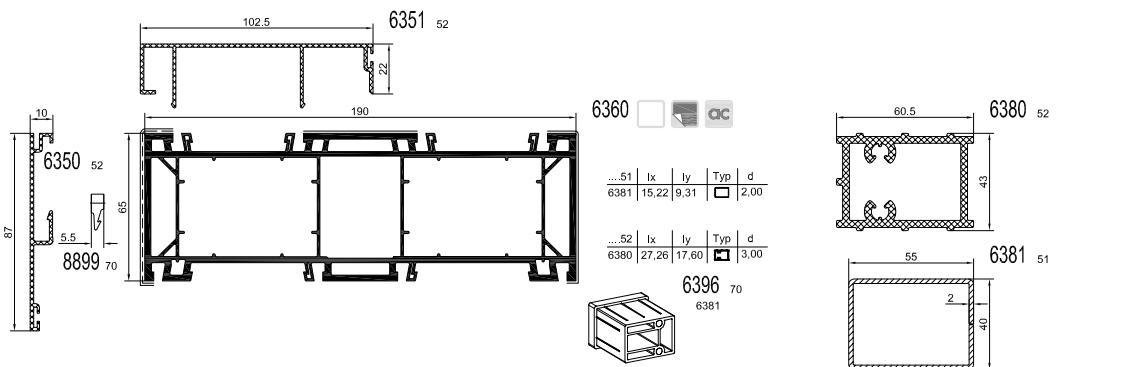

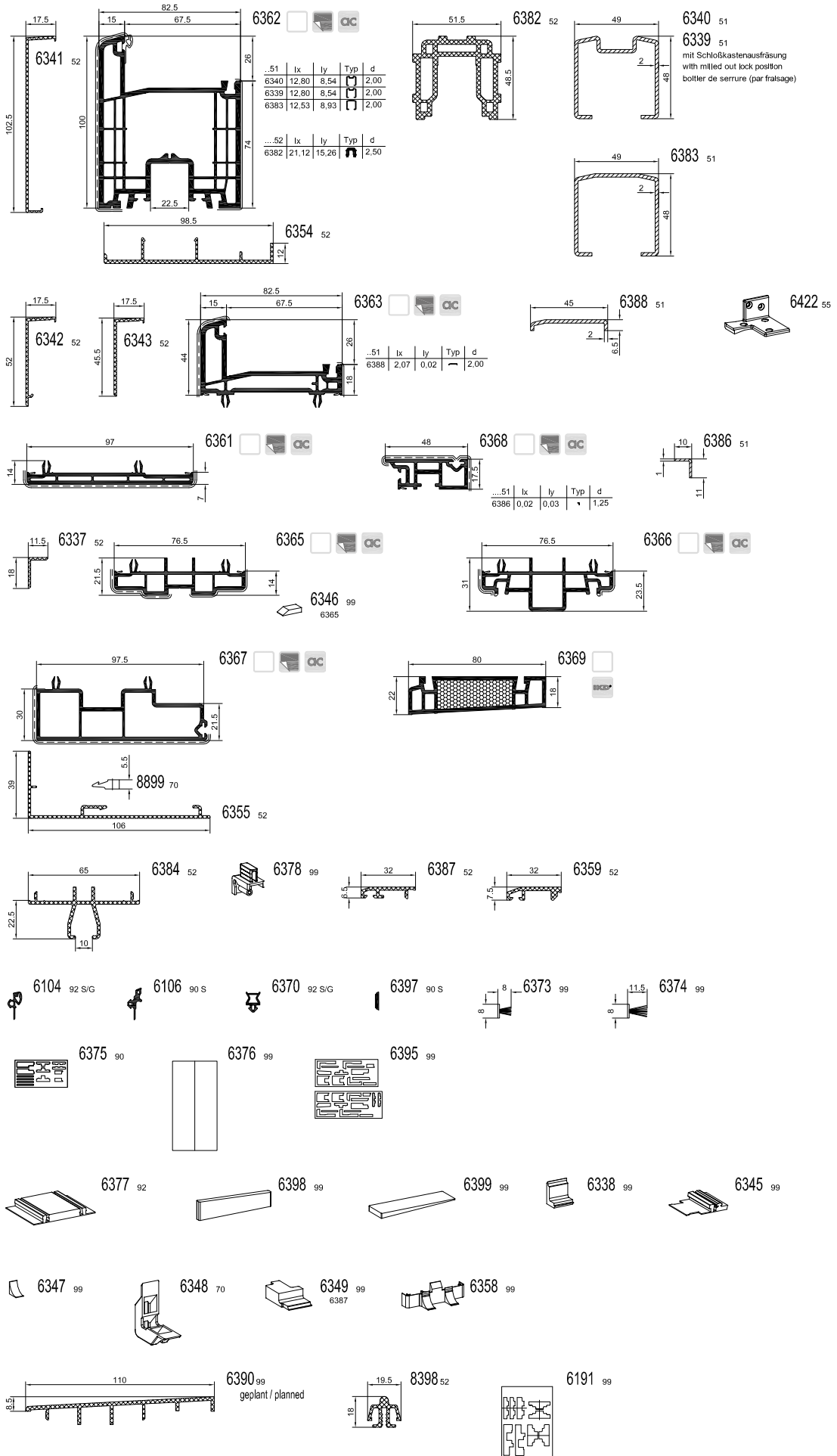

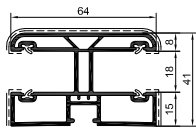

3347   



3429

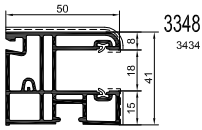

3348  

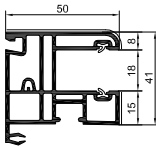

3349 



3434

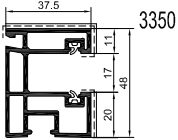

3350  

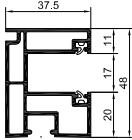

3351



3438



3439



3440

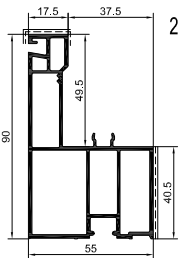

2225  

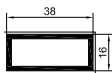

2312 



3406 ⁷⁰



3354 ⁹⁹



3352 ⁹⁹



8878 ⁹⁹

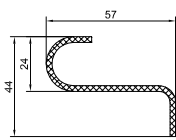

2503 ⁵²

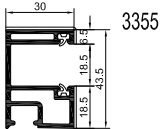

3355 



3436



3356 



3357 



2347

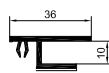

3345 

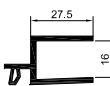

3346

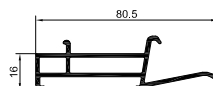

2207 

für 3347, 3348 und 3349 · for 3347, 3348 and 3349



3340

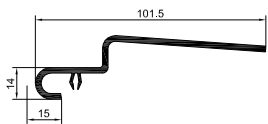

6211

für 3355, 3350 und 3351 · for 3355, 3350 and 3351



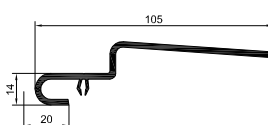

3342



5210

Legende · legend

-  **PVC weiß oder farbig durchgefärbt** · uPVC white or solid-coloured
-  **foliiert** · laminated
-  **PMMA außen farbig, auf PVC Grundkörper** · PMMA colour on uPVC
-  **PVC Profil mit Recyclingkern** · uPVC profile with recycling core
-  **Statische-Trocken-Verglasung STV®** · STV® static dry glazing
-  **Intensiv-Kern-Dämmung IKD®** · IKD® intensive core insulation
-51 **Stahl** · steel
-52 **Aluminium** · aluminium
-55 **Zinkdruckguss** · zinc diecasting
-70 **Kunststoffzubehör** · plastics accessories
-80 **Polyamid-Zubehör** · polyamide accessories
-90 **EPDM Dichtung** · EPDM gasket
-91 **Silikon** · silicone
-92 **TPE Dichtung** · TPE gasket
-93 **PVC weich** · Flexible PVC
-99 **Sonstige Materialien und Fensterzubehör** · other materials and window accessories
- **Profiloberfläche mit Dekor- oder Farbfolie** · surface laminated with wooden-structure or coloured film
- **PMMA-Oberfläche coextrudiert** · PMMA surface, coextruded
- lx und ly **Werte in cm⁴** · lx and ly value in cm⁴
-  **grau angelegte Profile in Vorbereitung** · grey profiles in process of realisation

Hinweis:

Der Inhalt dieser Profilübersicht ist unverbindlich! Das exakte Lieferprogramm entnehmen Sie bitte der aktuellen Übersicht „Profile und Zubehör“.

Please note:

The content of this compendium is not binding! See the exact product range in the summary „Profiles and Accessories“.